

貫通型端子台

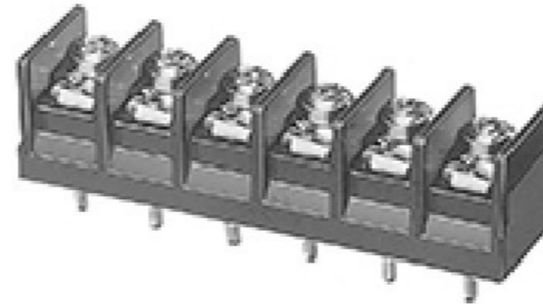

Through-type Terminal Block

ピッチ / Pitch 7.62mm

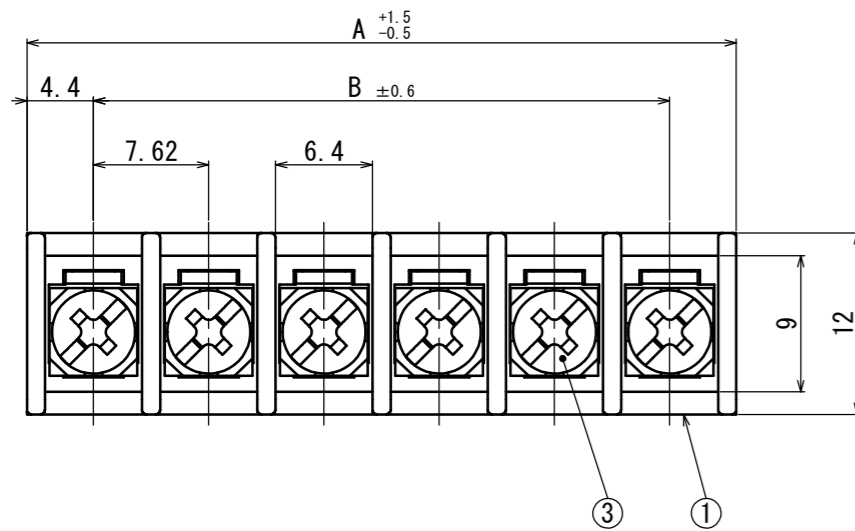

型名 Type Number	F 2 0 6 0 A X		
定格 Rating	AC 250V 10A~20A		
絶縁抵抗 Insulation Resistance	DC500V 1000Ω以上 DC500V 1000Ω and over		
耐電圧 Withstands Voltage	AC2000V 1分間以上 AC2000V 1minute and over		
ねじ径 Screw Diameter	M3		
使用可能電流 Usable Current	10A	15A	20A
適合電線 Compatible Wire	0.75mm ²	1.25mm ²	2mm ²
推奨圧着端子 Recommended Crimp Terminal	R0.75-3	R1.25-3	R2-3N

一般公差 / General Tolerance ±0.5

尺度 / Scale 1/10 単位 / Unit mm

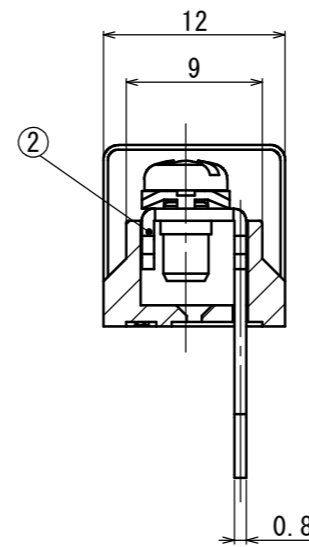
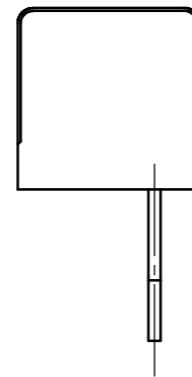
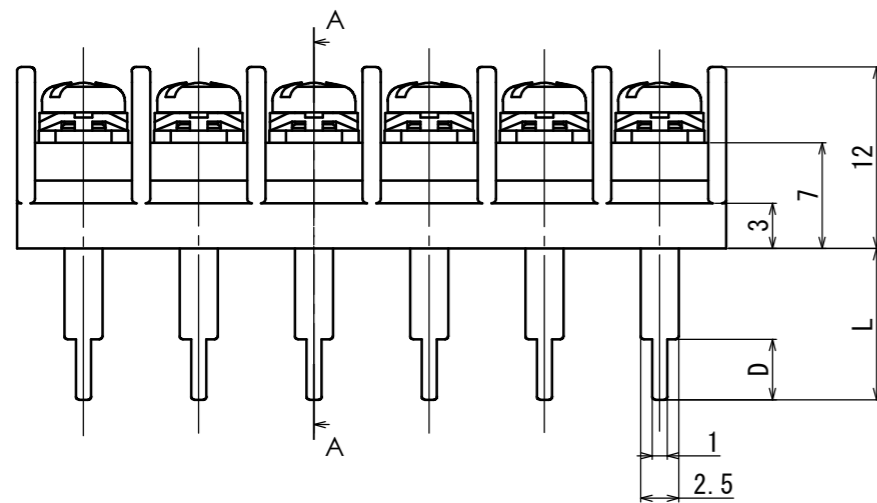

A-A 断面図
A-A Cross Section

呼び/Nominal	L	D
4L	4	4
6.5L	6.5	4.5
8.2L	8.2	4.5
10L	10	4
13.2	13.2	4
36.7L	36.7	4
48.2L	48.2	4

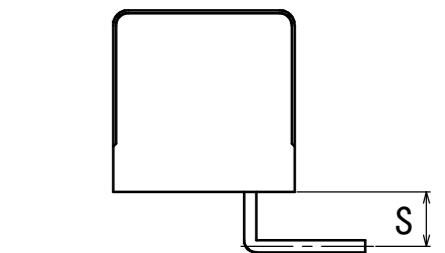

S: リード外曲げ加工例
Example of a lead bent outward

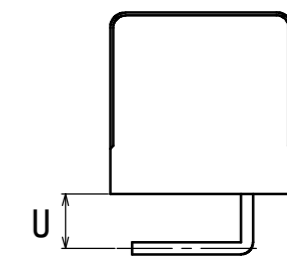

U: リード内曲げ加工例
Example of a lead bent inward

(曲げ希望時)

- ・注文方法: [型名] --- [リード長] L --- [曲げ寸法] S/U --- [極数] P.
- ・Ordering Form: Type No. Lead Length(L) Bent Length(S or U) No. of Poles(P)
(if bending is desired)
- ・結線ビス: 締付けトルク 0.6N・m.
- ・Connection screw: Tightening torque is 0.6N・m.
- ・その他オプション: ショートピース (F2131)
- ・Other options: Jumper (F2131)

仕様 / Specifications.

部番/Part No.	部番/Part No.	材質/Material	規格/Standard	寸法/Size	処理/Treatment	備考/Remark
1	基板 Base	PBT	UL			黒色 Black
2	導電板 Terminal	黄銅 Brass	C2680R	板厚 t0.8	スズメッキ Tin-Plated	
3	結線ビス Screw	鉄 Steel	SPWCH・SPCC	M3×0.5×6L	ニッケルメッキ Nickel-Plated	フリータンヒス Type②

極数/Poles	1P	2	3	4	5	6	7	8	9	10	11	12	13	14
A	8.8	16.4	24.0	31.7	39.3	46.9	54.5	62.1	69.8	77.4	85.0	92.6	100.2	107.9
B	-	7.62	15.24	22.86	30.48	38.1	45.72	53.34	60.96	68.58	76.20	83.82	91.44	99.06

極数/Poles	15P	16	17	18	19	20	21	22	23	24	25	26	27	28
A	115.5	123.1	130.7	138.3	146.0	153.6	161.2	168.8	176.4	184.0	191.7	199.3	206.9	214.5
B	106.68	114.3	121.92	129.54	137.16	144.78	152.24	160.02	167.64	175.26	182.88	190.5	198.12	205.74