

# 基板端子

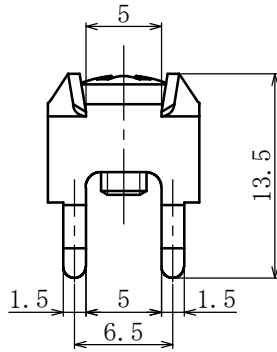

Printed board Terminal

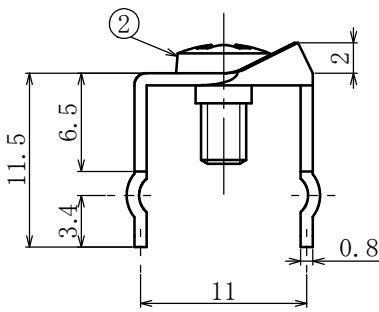
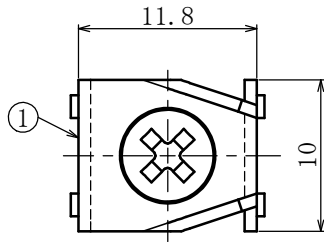

型名 Type Number	F4050A		
定格 Rating	20A~40A		
ねじ径 Screw Diameter	M3		
使用可能電流 Usable Current	20A	30A	40A
適合電線 Compatible Wire	2mm <sup>2</sup>	3.5mm <sup>2</sup>	5.5mm <sup>2</sup>
推奨圧着端子 Recommended Crimp Terminal	R2-3	R3.5-3	R5.5-3

一般公差 / General Tolerance ±0.5

尺度 / Scale  $\frac{2}{1}$  単位 / Unit mm

基板加工参考例  
Processing the reference printed board

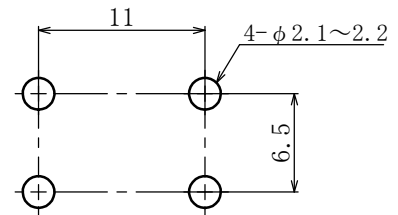

プリント基板厚: t1.4~2.0  
Printed board: t1.4~2.0

・注文方法: **型番** (下表の型番を御参照下さい。)

## 仕様 Specifications

・Ordering Form: Type No. (See the type number in the following table)

番号 Part No.	名称 Part Name	材質 Material	寸法 Size	規格 Standard	処理 Treatment
1	基板端子 Printed board Terminal	黄銅 Brass	板厚 t=0.8	C2680R	スズメッキ Tin-Plated
2	結線ビス Screw	黄銅 Brass		C2700W	ニッケルメッキ Nickel-Plated

型番 Type No.	納入される物 Product Delivered
F4050A	基板端子(M3用)のみ(ビスなし) Printed board terminal (for M3) only (W/O screws)
F4050AS	基板端子+M3×6Lバインドビス組付 Printed board terminal+M3×6L binding head attached

対応可能ビス Compatible screw	材質 Material	処理 Treatment	形状 Shape
PW・SWセムスパインド Type③With Plain(Flat)washer and spring lock washer	黄銅 Brass	ニッケルメッキ Nickel-Plated	Type③
	鉄 steel		
SWセムスパインド Type④With spring lock washer	黄銅 Brass	ニッケルメッキ Nickel-Plated	Type④
PW・SWセムスナベ Type⑤With Plain(Flat)washer and spring lock washer	黄銅 Brass	ニッケルメッキ Nickel-Plated	Type⑤
	鉄 steel		
SWセムスナベ Type⑦With spring lock washer	黄銅 Brass	ニッケルメッキ Nickel-Plated	Type⑦