

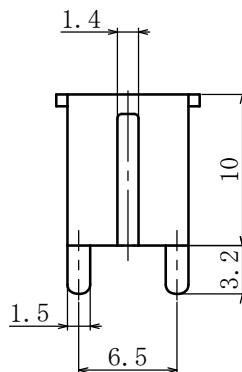

型名 Type Number	F 4 1 1 1 H		
定格 Rating	20 A ~ 40 A		
ねじ径 Screw Diameter	φ 3.6 穴		
使用可能電流 Usable Current	20 A	30 A	40 A
適合電線 Compatible Wire	2 mm ²	3.5 mm ²	5.5 mm ²
推奨圧着端子 Recommended Crimp Terminal	R 2-3	R 3.5-3	R 5.5-3

一般公差 / General Tolerance ±0.5

尺度 / Scale $\frac{2}{1}$ 単位 / Unit mm

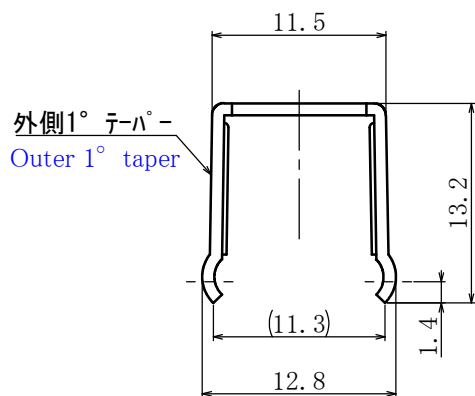
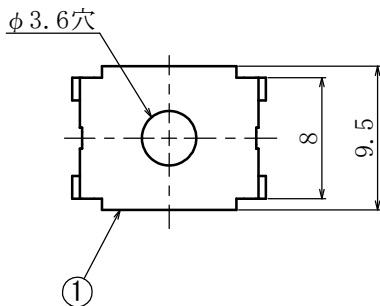

基板加工参考例
Processing the reference printed board

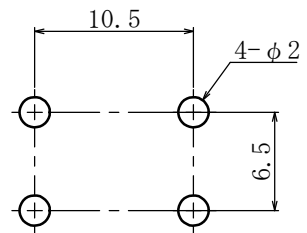

プリント基板厚: t1.4~2.0
Printed board: t1.4~2.0

・注文方法: **型番** (下表の型番を御参照下さい。)

■仕様 Specifications. ・Ordering Form: Type No. (See the type number in the following table)

番号 Part No.	名称 Part Name	材質 Material	寸法 Size	規格 Standard	処理 Treatment
1	基板端子 Printed board Terminal	黄銅 Brass	板厚 t=0.8	C2680R	スズメッキ Tin-Plated
—	—	—	—	—	—

型番 Type No.	納入される物 Product Delivered
F4111H	基板端子 (φ 3.6用) のみ (ビスなし) Printed board terminal (for φ 3.6) only (W/O screws)
—	—