

# 基板端子



Printed board Terminal



型名 Type Number	F 4 1 3 2 A		
定格 Rating	20A~40A		
ねじ径 Screw Diameter	M3		
使用可能電流 Usable Current	20A	30A	40A
適合電線 Compatible Wire	2mm <sup>2</sup>	3.5mm <sup>2</sup>	5.5mm <sup>2</sup>
推奨圧着端子 Recommended Crimp Terminal	R2-3	R3.5-3	R5.5-3

一般公差 / General Tolerance ±0.5

尺度 / Scale 1/1 単位 / Unit mm

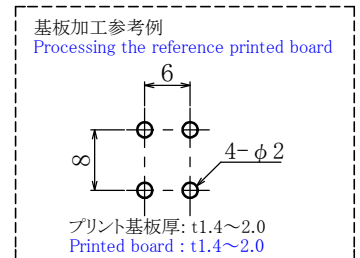
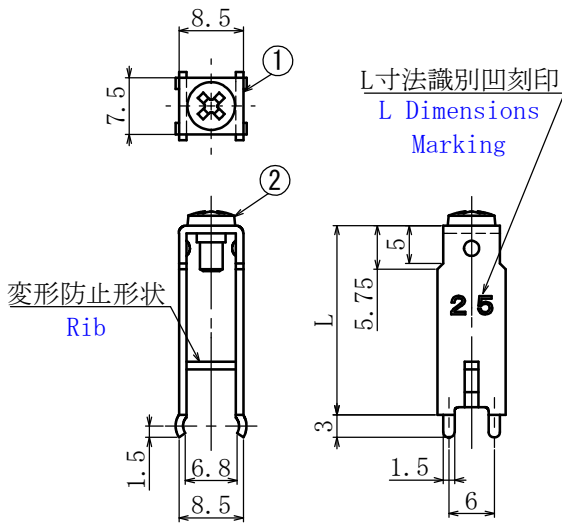

15L, 20L変形防止形状無し  
15L, 20L Rib Nothing

※結線する際は、必ず厚み1mm以上の圧着端子、プリント基板などの板を挟みねじを締付けること。  
※When connecting, be sure to sandwich a plate such as a crimp terminal or printed circuit board with a thickness of 1 mm or more and tighten the screws.

・注文方法: **型番** (下表の型番を御参照下さい。)

■仕様 Specifications. ・Ordering Form: Type No. (See the type number in the following table)

型番 Type No.	識別凹刻印 marking	L寸法 L Dimensions	変形防止形状 Rib
F4132A-15L	15	15	無し Nothing
F4132A-20L	20	20	無し Nothing
F4132A-25L	25	25	有り There is
F4132A-30L	30	30	有り There is
F4132A-35L	35	35	有り There is
F4132A-40L	40	40	有り There is
F4132A-45L	45	45	有り There is

番号 Part No.	名称 Part Name	材質 Material	寸法 Size	規格 Standard	処理 Treatment
1	基板端子 Printed board Terminal	黄銅 Brass	板厚 t=1.0	C2680R	スズメッキ Tin-Plated
2	結線ビス Screw	黄銅 Brass		C2700W	ニッケルメッキ Nickel-Plated

型番 Type No.	納入される物 Product Delivered
F4132A-15L	基板端子(M3用)のみ(ビスなし) Printed board terminal (for M3) only (W/O screws)
F4132A-20L	
F4132A-25L	
F4132A-30L	
F4132A-35L	
F4132A-40L	
F4132A-45L	
F4132AS-15L	基板端子+M3×6Lバインドビス組付 Printed board terminal+M3×6L binding head attached
F4132AS-20L	
F4132AS-25L	
F4132AS-30L	
F4132AS-35L	
F4132AS-40L	
F4132AS-45L	

対応可能ビス Compatible screw	材質 Material	処理 Treatment	形状 Shape
PW・SWセムスパインド Type③With Plain(Flat)washer and spring lock washer	黄銅 Brass	ニッケルメッキ Nickel-Plated	Type③
	鉄 steel		
SWセムスパインド Type④With spring lock washer	黄銅 Brass	ニッケルメッキ Nickel-Plated	Type④
PW・SWセムスナベ Type⑤With Plain(Flat)washer and spring lock washer	黄銅 Brass	ニッケルメッキ Nickel-Plated	Type⑤
	鉄 steel		
SWセムスナベ Type⑦With spring lock washer	黄銅 Brass	ニッケルメッキ Nickel-Plated	Type⑦