

貫通型端子盤

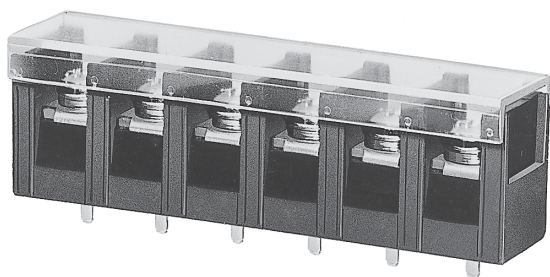

Through-type Terminal Block

貫通型



ピッチ/Pitch 10mm

型名 Type Number	F2028P-1X
定格 Rating	AC250V 20A
絶縁抵抗 Insulation Resistance	500V 1000MΩ以上 DC500V 1000MΩ and over
耐電圧 Withstands Voltage	2000V 1分間以上 AC2000V 1 minute and over
適合電線 Compatible Wire	2.0mm ²

一般公差/General Tolerance ±0.5

尺度/Scale 1/1 単位/Unit mm

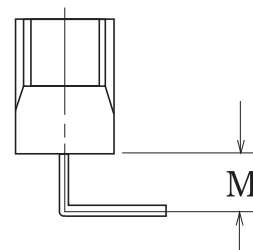
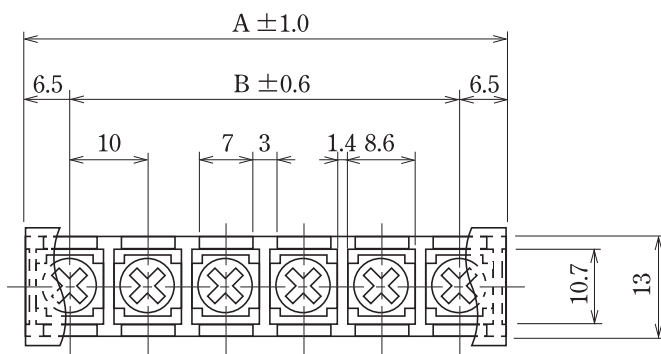

リード曲げ加工例
Example of a lead bent

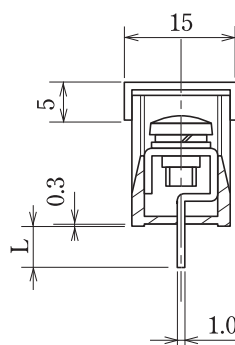
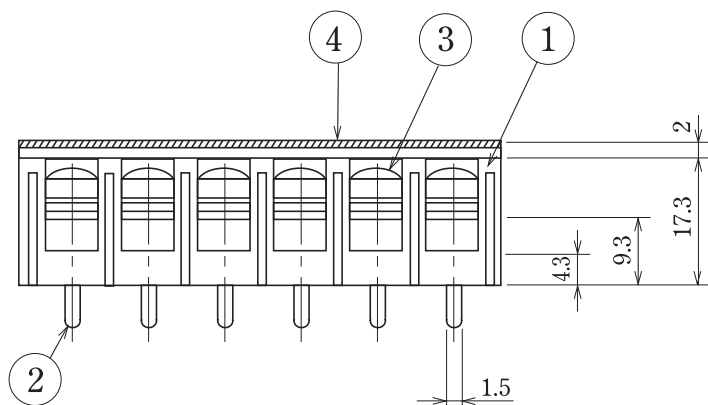

呼び/Nominal	L
4L	4
15L	15
20L	20
30L	30
45L	45

- 注文方法: 型名 — リード長 L — (曲げ希望時) 曲げ寸法 M — 極数 P.
- Ordering Form: Type No. Lead Length (L) Bent Length (M) No. of Poles (P)

● 結線ビス: 締付トルクは1.4N・mです。

● Connection screw: Tightening torque is 1.4 N・m.

● カバーはオプションとなっておりますのでご希望の際は注文方法の末尾に-CTとご記入ください。(INDEX参照)

● A cover is optional. To obtain one, and "-CT" to the end of the order description shown above. (See INDEX for specifications)

A cover will be delivered attached. Other options *Jumper (F2133) *Mt. metal fitting (F9013, F9015, F9050, F9089, F9090, F9097)

仕様/Specifications.

部番/Part No.	名称/Part Name	材質/Material	規格/Standard	寸法/Size	処理/Treatment	備考/Remark
1	基板 Base	PBT	UL			黒色 Black
2	導電板 Terminal	黄銅 Brass	C2680R	板厚 t 1.0	スズメッキ Tin-Plated	
3	結線ビス Screw	黄銅 Brass	C2700W	M4×0.7×8ℓ	ニッケルメッキ Nickel-Plated	PWSWセムスパインド Type③
4	カバー Cover	ポリカーボネート Polycarbonate	UL	板厚 t 1.0	透明 Transparence	オプション Optional

極数/Poles	1P	2	3	4	5	6	7	8	9	10	11	12	13	14	15	16	17	18	19	20	21	22
A	13	23	33	43	53	63	73	83	93	103	113	123	133	143	153	163	173	183	193	203	213	223
B	-	10	20	30	40	50	60	70	80	90	100	110	120	130	140	150	160	170	180	190	200	210

極数/Poles	23	24
A	233	243
B	220	230