

貫通型

プリント基板用

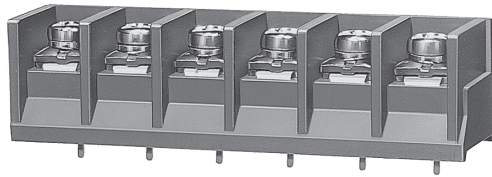

ピッチ/Pitch 9.5mm

型名 Type Number	F2044SX	
定格 Rating	AC250V 15A	
絶縁抵抗 Insulation Resistance	500V	1000MΩ 以上 DC500V 1000MΩ and over
耐電圧 Withstands Voltage	2000V	1 分間以上 AC2000V 1 minute and over
適合電線 Compatible Wire	1.25mm ²	

一般公差/General Tolerance ±0.5

尺度/Scale 1/1 単位/Unit mm

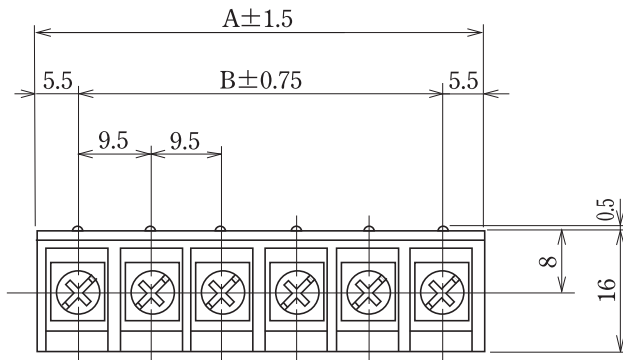

呼び/Nominal	L
4 L	4
10L	10

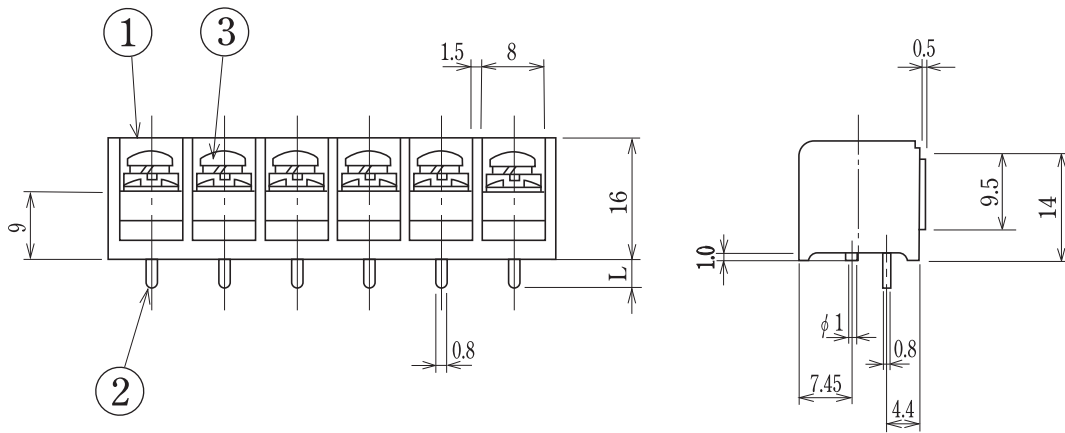

- 注文方法：型名 — リード長 L — 極数 P.
- Ordering Form : Type No. Lead Length (L) No. of Poles (P)
- 結線ビス：締付トルクは1.0N・mです。
- Connection screw : Tightening torque is 1.0 N・m.
- その他オプション *ショートピース (F2111、F2111B)
- Other options *Jumper (F2111、F2111B)

■仕様/Specifications.

部番/Part No.	名称/Part Name	材質/Material	規格/Standard	寸法/Size	処理/Treatment	備考/Remark
1	基板 Base	PBT	UL			黒色 Black
2	導電板 Terminal	黄銅 Brass	C2680R	板厚 t 0.8	スズメッキ Tin-Plated	
3	結線ビス Screw	鉄 Steel	SWCH・SPCC	M3.5×0.6×8ℓ	ニッケルメッキ Nickel-Plated	フリータンシビス Type①

極数/Poles	1P	2	3	4	5	6	7	8	9	10	11	12	13	14	15	16	17	18	19	20	21	22
A	12.5	20.5	30.0	39.5	49.0	58.5	68.0	77.5	87.0	96.5	106.0	115.5	125.0	134.5	144.0	153.5	163.0	172.5	182.0	191.5	201.0	210.5
B	-	9.5	19.0	28.5	38.0	47.5	57.0	66.5	76.0	85.5	95.0	104.5	114.0	123.5	133.0	142.5	152.0	161.5	171.0	180.5	190.0	199.5

極数/Poles	23	24	25	26	27	28	29	30	31	32
A	220.0	229.5	239.0	248.5	258.0	267.5	277.0	286.5	296.0	305.5
B	209.0	218.5	228.0	237.5	247.0	256.5	266.0	275.5	285.0	294.5