

ねじなし端子盤

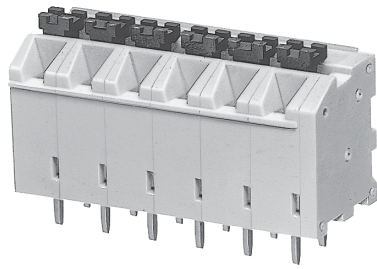

No screw-type Terminal Block



ピッチ/Pitch 5 mm

型名 Type Number	F6013AL
定格 Rating	AC250V 10A
絶縁抵抗 Insulation Resistance	500V 1000MΩ以上 DC500V 1000MΩ and over
耐電圧 Withstands Voltage	2000V 1分間以上 AC2000V 1 minute and over
適合電線 Compatible Wire	本文を御参照下さい Refer to the text

一般公差/General Tolerance ±0.3

尺度/Scale 1/1 単位/Unit mm

A・B寸法公差

1~5P	±0.5
6~10P	±0.6
11~15P	±0.85
16~20P	±1.0
21~30P	±1.6

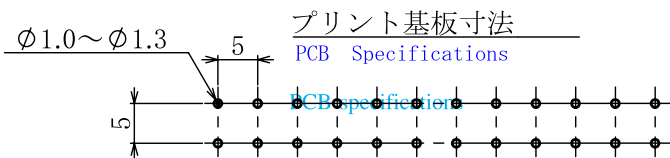
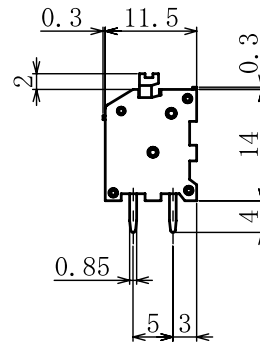
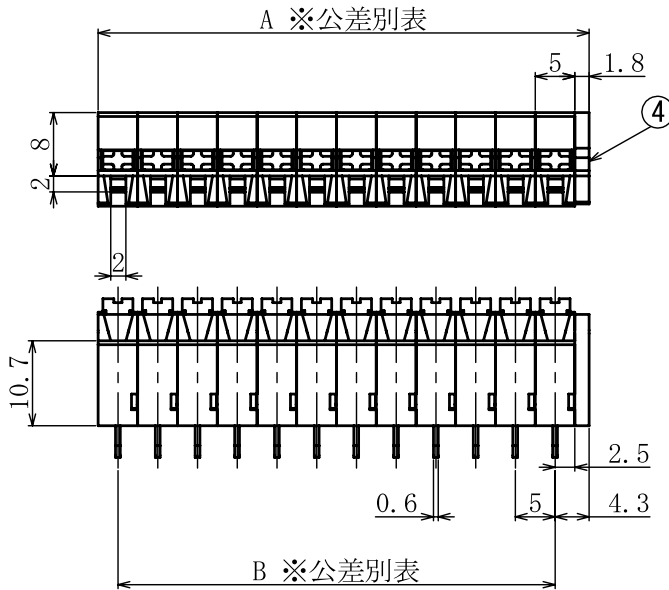

- 注文方法：型名 — 極数 P. — 色指定 (スカイブルー・黄・ベージュ・緑)
- Ordering Form : Type No. No. of Poles (P) Designation of Color (Skyblue・Yellow・Beige・Green)
- 電線の接続、解除はマイナスドライバーで行う。
- The wire should be connected and disconnected with a minus driver.
- 適合電線：0.3~1.25mm² (より線), φ0.4~1.2 (単線)
- Compatible wire : 0.3~1.25 mm² (Stranded wire). φ0.4~1.2 (solid wire)
- 線むき長さ：7~10mm
- Stripped wire Length : 7~10 mm

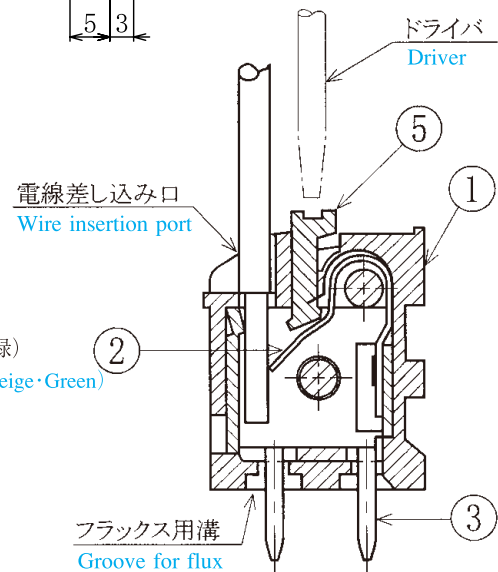

仕様/Specifications.

部番/Part No.	名称/Part Name	材質/Material	規格/Standard	寸法/Size	処理/Treatment	備考/Remark
1	基板 Base	ナイロン66 Nylon 66	UL			スカイブルー・黄色・ベージュ・緑色 Skyblue・Yellow・Beige・Green
2	ワイヤークランプ Wire clamp spring	ステンレス Stainless steel	SUS304			
3	接触板 Contact plate	黄銅 Brass	C2680R		スズメッキ Tin-Plated	
4	エンドプレート End plate	ナイロン66 Nylon 66	UL			スカイブルー・黄色・ベージュ・緑色 Skyblue・Yellow・Beige・Green
5	ノブ Knob	PPS	UL			黒色 Black

極数/Poles	1P	2	3	4	5	6	7	8	9	10	11	12	13	14	15	16	17	18	19	20	21	22
A	6.8	11.8	16.8	21.8	26.8	31.8	36.8	41.8	46.8	51.8	56.8	61.8	66.8	71.8	76.8	81.8	86.8	91.8	96.8	101.8	106.8	111.8
B	-	5.0	10.0	15.0	20.0	25.0	30.0	35.0	40.0	45.0	50.0	55.0	60.0	65.0	70.0	75.0	80.0	85.0	90.0	95.0	100.0	105.0

極数/Poles	23	24	25	26	27	28	29	30
A	116.8	121.8	126.8	131.8	136.8	141.8	146.8	151.8
B	110.0	115.0	120.0	125.0	130.0	135.0	140.0	145.0

ねじなし端子盤