

型名 Type Number	F9039
-------------------	--------------

一般公差 / General Tolerance ±0.5

尺度 / Scale 2/1 単位 / Unit mm

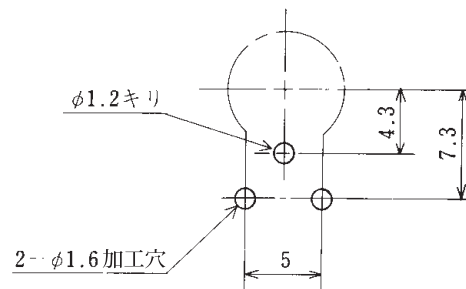
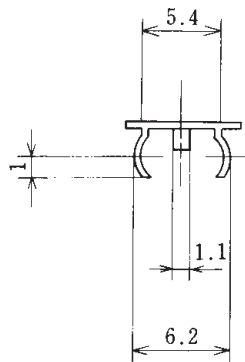
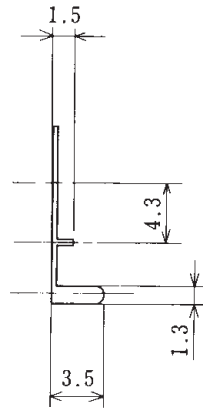
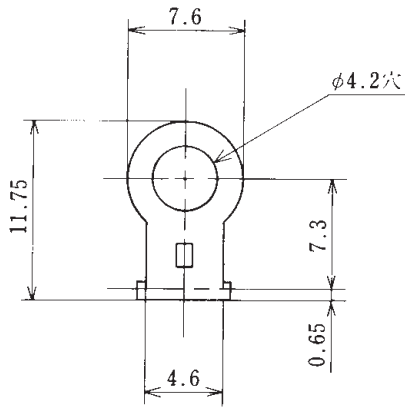

プリント基板加工図
Processing the printed board

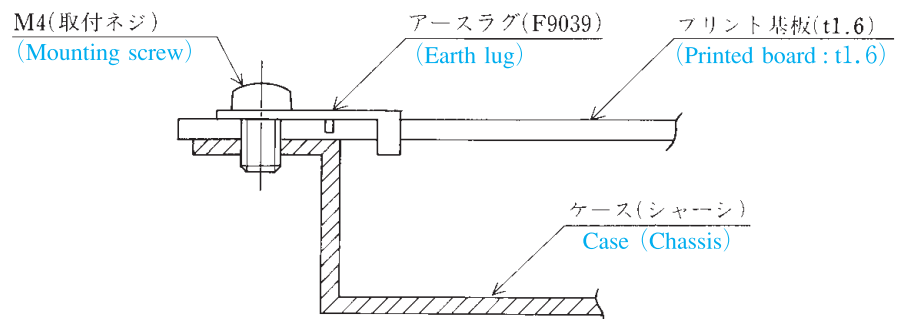

使用例
Example

- 注文方法 : 型名
- Ordering Form : Type No.

■仕様 / Specifications.

材質 / Material	規格 / Standard	寸法 / Size	処理 / Treatment	備考 / Remark
黄銅 Brass	C2680R	板厚 t 0.4	スズメッキ Tin-Plated	