

型名 Type Number	F9097
-------------------	-------

一般公差 / General Tolerance ±0.5

尺度 / Scale 2/1 単位 / Unit mm

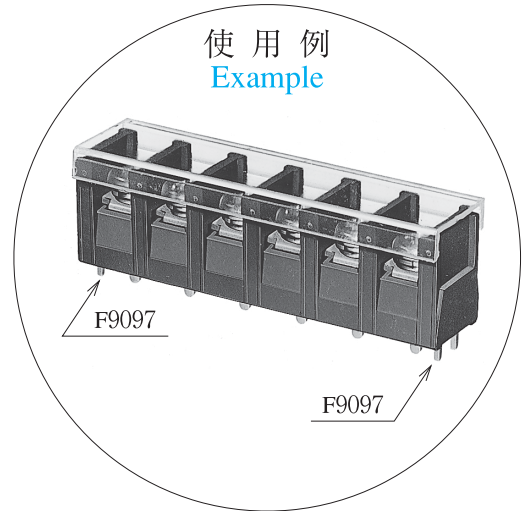
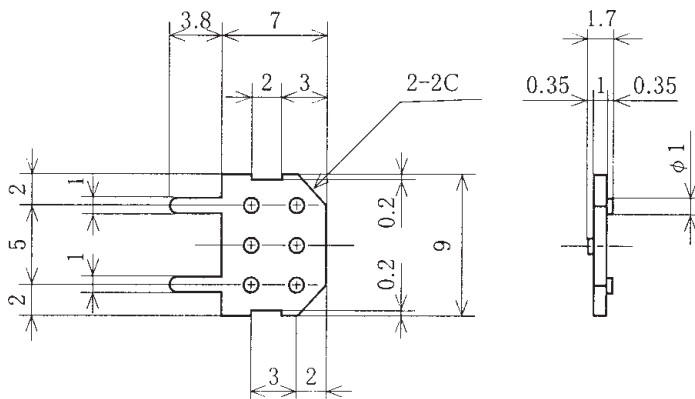
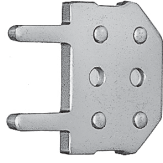

セット寸法例  
Example of dimension for SET

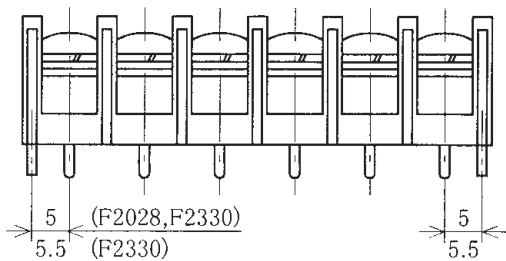

左右端リード中心より補強金具中心までの距離。  
Distance between center of lead at right and left end and center of on the Mounting metal fitting.

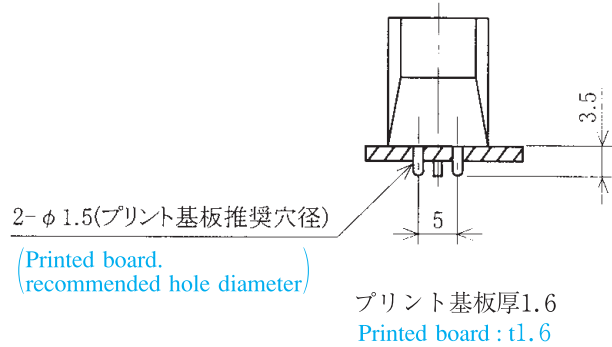

- 注文方法：型名
- Ordering Form : Type No.
- 注意：この補強金具は F2028AX、P-1X、F2323AX、P-1X、F2330AX、P-1X 専用です。
- Note : This mounting metal fitting is exclusively for F2028AX, P-1X, F2323AX, P-1X and F2330AX, P-1X.
- 極数によっては、補強金具取付が出来ない場合がありますので、事前にお問い合わせ下さい。
- Please ask us in advance for information, because there are some cases where mounting metal fittings do not apply in certain case of pole number.

■仕様 / Specifications.

材質 / Material	規格 / Standard	寸法 / Size	処理 / Treatment	備考 / Remark
黄銅 Brass	C2680R	板厚 t 1.0	スズメッキ Tin-Plated	