

ピッチ/Pitch 11mm

型名 Type Number	UF2038BP
定格 Rating	AC250V 20A
絶縁抵抗 Insulation Resistance	500V 1000MΩ 以上 DC500V 1000MΩ and over
耐電圧 Withstands Voltage	2000V 1分間以上 AC2000V 1 minute and over
適合電線 Compatible Wire	12-22AWG

一般公差/General Tolerance ±0.5

尺度/Scale 1/1 単位/Unit mm

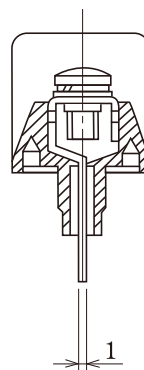
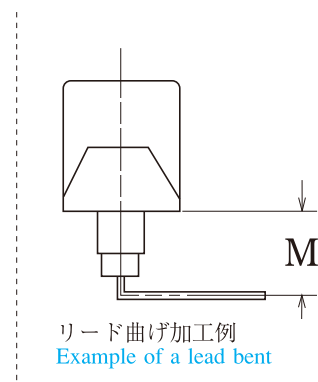
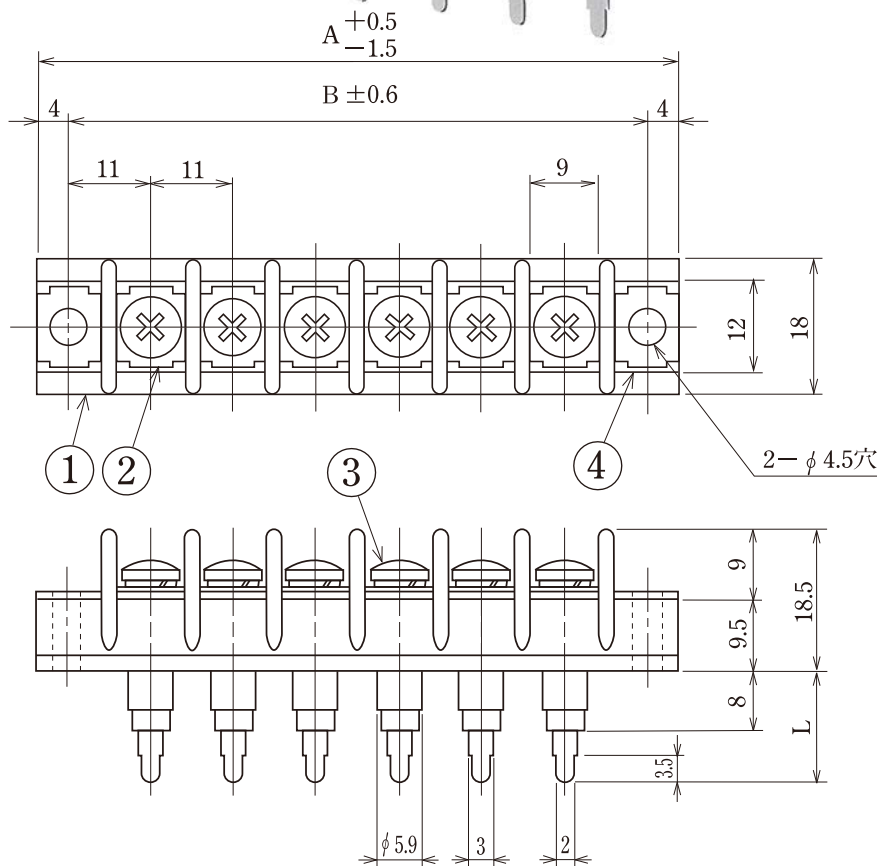

呼び/Nominal	L	M
15L	15	—
20L	20	11~14
28.5L	28.5	11~23

但しM寸法は3mm単位とします。
But, size of M is available as 3mm increment.

● 注文方法: 型名 — リード長 L — (曲げ希望時) 曲げ寸法 M — 極数 P.

● Ordering Form: Type No. Lead Length (L) Bent Length (M) No. of Poles (P)
(if bending is desired)

● 結線ビス: 締付トルクは1.4N・mです。又別仕様についてはINDEXを御参照下さい。

● Connection screw: Tightening torque is 1.4 N・m. See INDEX for other specifications.

● 用途: 市販(商業用)器具・事務用設備、電子式データ処理設備等及び一般産業用。

● Application: Commercial appliances, including business equipment, electronic data processing equipment, etc. and general industrial.

■仕様/Specifications.

部番/Part No.	名称/Part Name	材質/Material	規格/Standard	寸法/Size	処理/Treatment	備考/Remark
1	基板 Base	PBT	UL			黒色 Black
2	導電板 Terminal	黄銅 Brass	C2680R	板厚 t 1.0	スズメッキ Tin-Plated	
3	結線ビス Screw	黄銅 Brass	C2700W	M4×0.7×8ℓ	ニッケルメッキ Nickel-Plated	PWSWセムスパインド Type③
4	取付金具 Mounting plate	黄銅 Brass	C2680R	板厚 t 1.0	ニッケルメッキ Nickel-Plated	

極数/Poles	1P	2	3	4	5	6	7	8	9	10	11	12	13	14	15	16	17	18	19	20	21	22
A	30	41	52	63	74	85	96	107	118	129	140	151	162	173	184	195	206	217	228	239	250	261
B	22	33	44	55	66	77	88	99	110	121	132	143	154	165	176	187	198	209	220	231	242	253

極数/Poles	23	24
A	272	283
B	264	275

海外規格
認定品

貫通型