

ピッチ/Pitch 9.5mm

型名 Type Number	UF2048B
定格 Rating	AC250V 15A
絶縁抵抗 Insulation Resistance	500V 1000MΩ 以上 DC500V 1000MΩ and over
耐電圧 Withstands Voltage	2000V 1 分間以上 AC2000V 1 minute and over
適合電線 Compatible Wire	16-22AWG

一般公差/General Tolerance ±0.5

尺度/Scale 1/1 単位/Unit mm

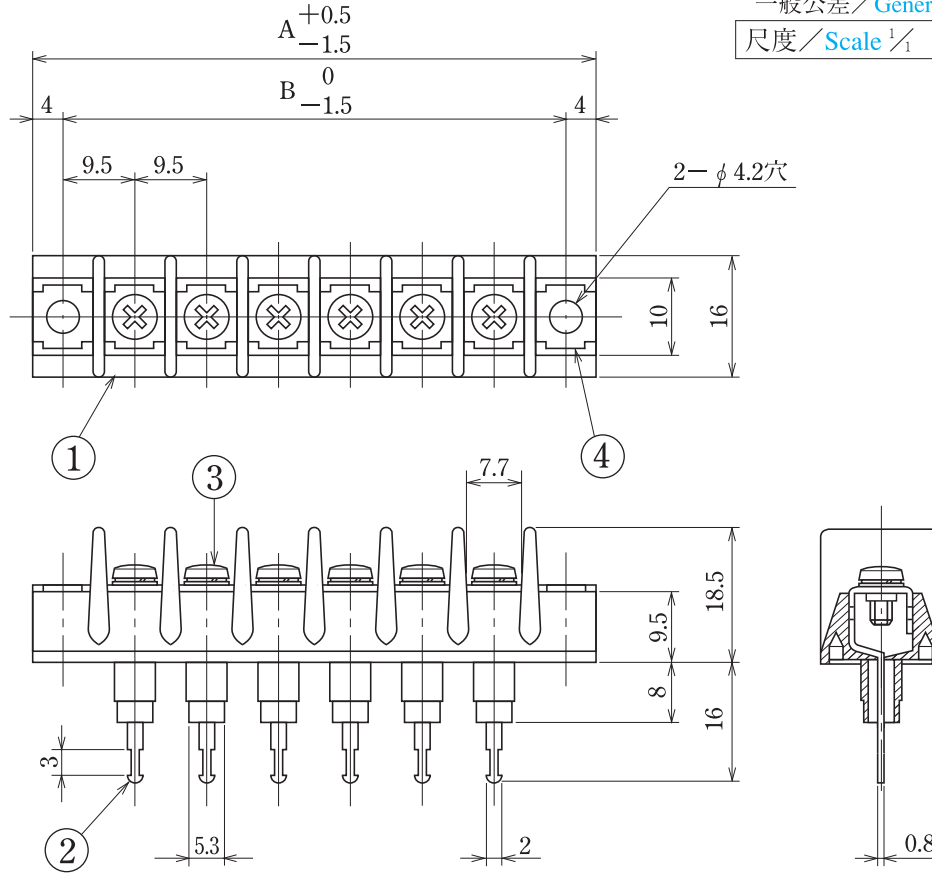

海外
認定
規格

貫
通
型

- 注文方法：型名 — 極数 P.
- Ordering Form : Type No. No. of Poles (P)
- 結線ビス：締付トルクは M3 が0.6N・m、M3.5 が1.0N・m です。又別仕様については INDEX を御参照下さい。
- Connection screw : Tightening torque is M3 : 0.6N・m, M3.5 : 1.0 N・m. See INDEX for other specifications.
- 用途：市販（商業用）器具・事務用設備、電子式データ処理設備等及び一般産業用。
- Application : Commercial appliances, including business equipment, electronic data processing equipment, etc. and general industrial.

■仕様/Specifications.

部番/Part No.	名称/Part Name	材質/Material	規格/Standard	寸法/Size	処理/Treatment	備考/Remark
1	基板 Base	PBT	UL			黒色 Black
2	導電板 Terminal	黄銅 Brass	C2680R	板厚 t 0.8	スズメッキ Tin-Plated	
3	結線ビス Screw	黄銅 Brass	C2700W	M3×0.5×8 ℓ	ニッケルメッキ Nickel-Plated	PWSWセムスパインド Type③
4	取付金具 Mounting plate	黄銅 Brass	C2680R	板厚 t 1.0	ニッケルメッキ Nickel-Plated	

極数/Poles	1P	2	3	4	5	6	7	8	9	10	11	12	13	14	15	16	17	18	19	20	21	22
A	27.0	36.5	46.0	55.5	65.0	74.5	84.0	93.5	103.0	112.5	122.0	131.5	141.0	150.5	160.0	169.5	179.0	188.5	198.0	207.5	217.0	226.5
B	19.0	28.5	38.0	47.5	57.0	66.5	76.0	85.5	95.0	104.5	114.0	123.5	133.0	142.5	152.0	161.5	171.0	180.5	190.0	199.5	209.0	218.5

極数/Poles	23	24	25	26
A	236.0	245.5	255.0	264.5
B	228.0	237.5	247.0	256.5