

Ⓡタイプ
Type

ピッチ/Pitch 7.62mm

型名 Type Number	UF2069ALX
定格 Rating	AC250V 10A
絶縁抵抗 Insulation Resistance	500V 1000MΩ 以上 DC500V 1000MΩ and over
耐電圧 Withstands Voltage	2000V 1 分間以上 AC2000V 1 minute and over
適合電線 Compatible Wire	14-22AWG

一般公差/General Tolerance ±0.5

尺度/Scale 1/4 単位/Unit mm

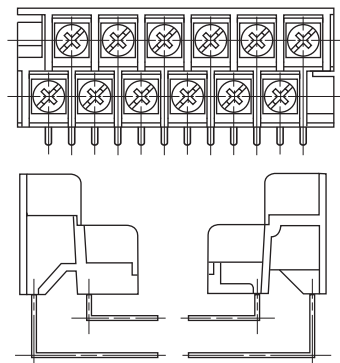
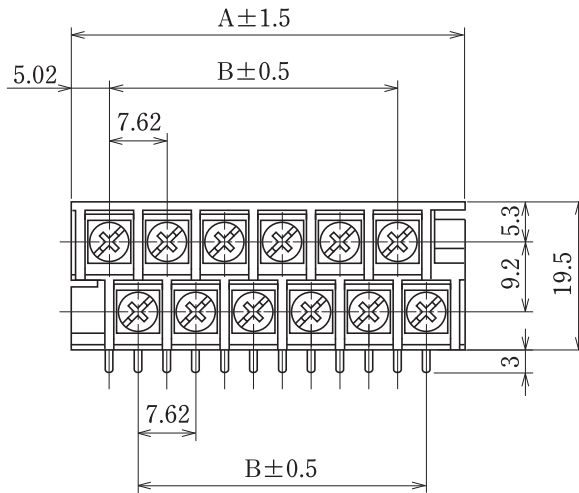

Ⓡタイプの場合
In case of Type Ⓡ

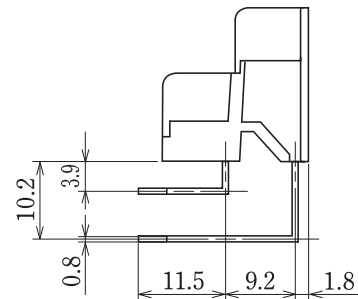
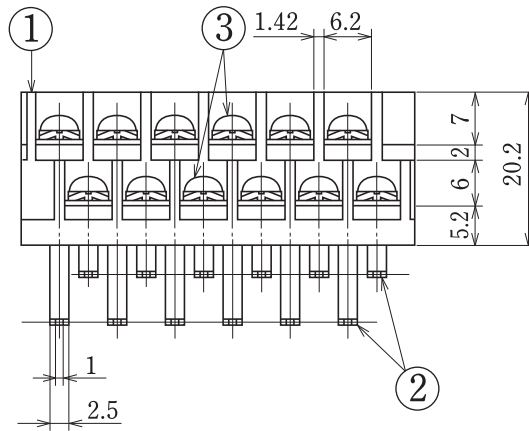

海外
認定
規格

2 段型

- 注文方法：型名 R 極数 P.
- Ordering Form : Type No. (R or L) No. of Poles (P)
- 切断方法によりRタイプとLタイプがありますのでご指定下さい。
- Spesifi either type R or L for a cutting surface (by a cutting process).
- 結線ビス：締付トルクは0.6N・mです。
- Connection screw : Tightening torque is 0.6 N・m.
- 用途：市販（商業用）器具—事務用設備、電子式データ処理及び工業用で制限された定格を持つ装置。
- Application : Commercial appliances, including business equipment, electronic data processing equipment, etc.
or industrial devices having limited ratings.

■仕様/Specification.

部番/Part No.	名称/Part Name	材質/Material	規格/Standard	寸法/Size	処理/Treatment	備考/Remark
1	基板 Base	PBT	UL			黒色 Black
2	導電板 Terminal	黄銅 Brass	C2680R	板厚 t 0.8	スズメッキ Tin-Plated	
3	結線ビス Screw	鉄 Steel	SWCH・SPCC	M3×0.5×6ℓ	ニッケルメッキ Nickel-Plated	フリータンシビス Type②

極数/Poles	2 P	4	6	8	10	12	14	16	18	20	22	24	26	28	30	32	34	36
A	13.85	21.47	29.09	36.71	44.33	51.95	59.57	67.19	74.81	82.43	90.05	97.67	105.29	112.91	120.53	128.15	135.77	143.39
B	-	7.62	15.24	22.86	30.48	38.10	45.72	53.34	60.96	68.58	76.20	83.82	91.44	99.06	106.68	114.30	121.92	129.54