

ピッチ/Pitch 10 mm

型名 Type Number	UF2326AX	
定格 Rating	AC250V (AC150V)	15A
絶縁抵抗 Insulation Resistance	500V 1000MΩ 以上 DC500V 1000MΩ and over	
耐電圧 Withstands Voltage	2000V 1 分間以上 AC2000V 1 minute and over	
適合電線 Compatible Wire	14-22AWG	

一般公差/General Tolerance ±0.5

尺度/Scale 1/4 単位/Unit mm

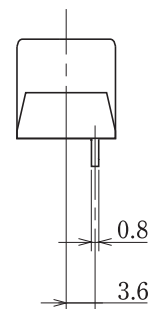
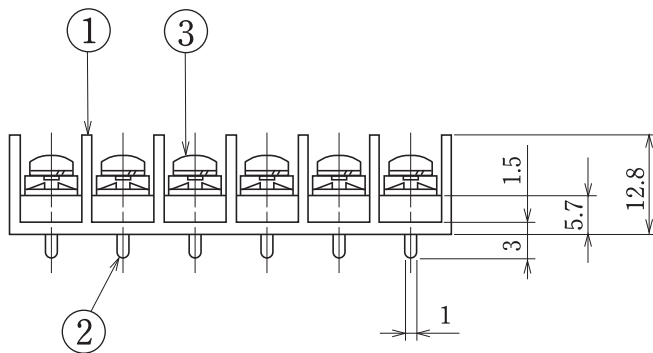
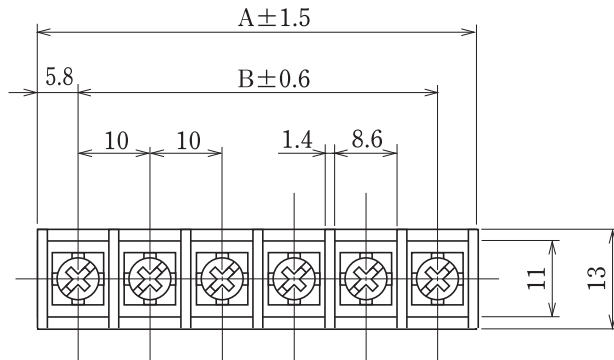

- 注文方法：型名 極数 P.
- Ordering Form : Type No. No. of Poles (P)
- 結線ビス：締付トルクは0.6N・mです。又、別仕様についてはINDEXを御参照ください。
- Connection screw : Tightening torque is 0.6N・m. See INDEX for other specifications.
- 用途：250Vは市販（商業用）器具—事務用設備、電子式データ処理設備等又は、工業用で制限された定格を持つ装置（10A）。150Vは一般産業用。
- Application : The 250V type is commercial appliances, including business equipment, electronic data processing equipment, etc. or industrial devices having limited ratings(10A). The 150V type is general industrial.

■仕様/Specification.

部番/Part No.	名称/Part Name	材質/Material	規格/Standard	寸法/Size	処理/Treatment	備考/Remark
1	基板 Base	PBT	UL			黒色 Black
2	導電板 Terminal	黄銅 Brass	C2680R	板厚 t 0.8	スズメッキ Tin-Plated	
3	結線ビス Screw	鉄 Steel	SWCH・SPCC	M3×0.5×6 ℓ	ニッケルメッキ Nickel-Plated	フリータンシビス Type②

極数/Poles	1P	2	3	4	5	6	7	8	9	10	11	12	13	14	15	16	17	18	19	20	21	22
A	11.6	21.6	31.6	41.6	51.6	61.6	71.6	81.6	91.6	101.6	111.6	121.6	131.6	141.6	151.6	161.6	171.6	181.6	191.6	201.6	211.6	221.6
C	—	10.0	20.0	30.0	40.0	50.0	60.0	70.0	80.0	90.0	100.0	110.0	120.0	130.0	140.0	150.0	160.0	170.0	180.0	190.0	200.0	210.0

極数/Poles	23	24	25	26
A	231.6	241.6	251.6	261.6
C	220.0	230.0	240.0	250.0