

ピッチ/Pitch 11mm

型名 Type Number	<b>UF2331P-1</b>
定格 Rating	AC250V 20A (AC150V 15A) AC300V 10A (AC600V 5A)
絶縁抵抗 Insulation Resistance	500V 1000MΩ 以上 DC500V 1000MΩ and over
耐電圧 Withstands Voltage	2000V 1分間以上 AC2000V 1 minute and over
適合電線 Compatible Wire	12-22AWG

一般公差/General Tolerance ±0.5

尺度/Scale 1/4 単位/Unit mm

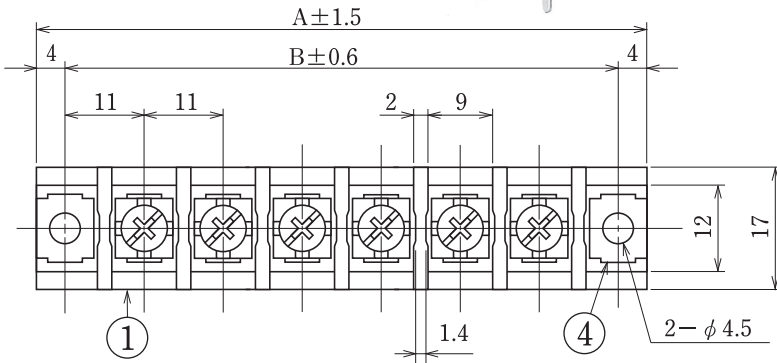

呼び/Nominal	L
4 L	3.8
15L	14.8
20L	19.8
30L	29.8
45L	44.8

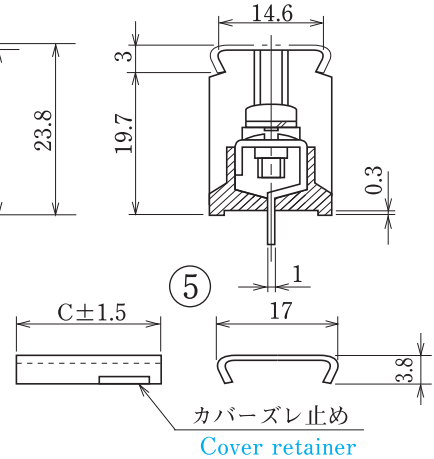
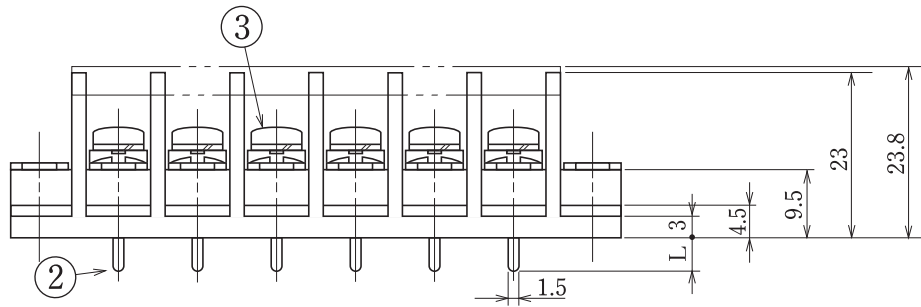
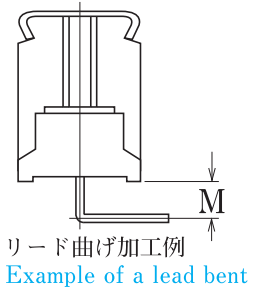

- 注文方法: 型名 [ ] リード長 L [ ] (曲げ希望時) 曲げ寸法 M [ ] 極数 P [ ]
- Ordering Form: Type No. [ ] Lead Length (L) [ ] Bent Length (M) [ ] No. of Poles (P) [ ]  
(if bending is desired)

- 結線ビス: 締付トルクは1.4N・mです。又、別仕様についてはINDEXを御参照ください。
- Connection screw: Tightening torque is 1.4 N·m. See INDEX for other specifications.
- カバーはオプションとなっておりますので御希望の際は注文方法の末尾に-CTと御記入ください。但しカバーは添付納入となります。
- A cover is optional. To obtain one, add "-CT" to the end of the order description shown above. A cover will be delivered attached.
- 用途: 600Vは工業用で制限された定格を持つ装置(150V:15A, 300V:10A, 600V:5A)。250Vは一般産業用。
- Application: The 600V type is industrial devices having limited ratings (150V:15A, 300V:10A, 600V:5A). The 250V type is general industrial.

■仕様/Specifications.

部番/Part No.	名称/Part Name	材質/Material	規格/Standard	寸法/Size	処理/Treatment	備考/Remark
1	基板 Base	PBT	UL			黒色 Black
2	導電板 Terminal	黄銅 Brass	C2680R	板厚 t 1.0	スズメッキ Tin-Plated	
3	結線ビス Screw	鉄 Steel	SWCH・SPCC	M4×0.7×8ℓ	ニッケルメッキ Nickel-Plated	フリータンシビス Type①
4	取付金具 Mounting plate	黄銅 Brass	C2680R	板厚 t 1.0	ニッケルメッキ Nickel-Plated	
5	カバー Cover	ポリカーボネート Polycarbonate	UL	板厚 t 0.8	透明 Transparence	オプション Optional

極数/Poles	1P	2	3	4	5	6	7	8	9	10	11	12	13	14	15	16	17	18	19	20	21	22
A	30.0	41.0	52.0	63.0	74.0	85.0	96.0	107.0	118.0	129.0	140.0	151.0	162.0	178.0	184.0	195.0	206.0	217.0	228.0	239.0	250.0	261.0
B	22.0	33.0	44.0	55.0	66.0	77.0	88.0	99.0	110.0	121.0	132.0	143.0	154.0	165.0	176.0	187.0	198.0	209.0	220.0	231.0	242.0	253.0
C	13.5	24.5	35.5	46.5	57.5	68.5	79.5	90.5	101.5	112.5	123.5	134.5	145.5	156.5	167.5	178.5	189.5	200.5	211.0	222.5	233.5	244.5

極数/Poles	23	24
A	272.0	283.0
B	264.0	275.0
C	255.5	266.5

海外規格  
認定品  
貫通型