

基板端子



Printed board Terminal



型名 Type Number	F4050A		
定格 Rating	20A~40A		
ねじ径 Screw Diameter	M3		
使用可能電流 Usable Current	20A	30A	40A
適合電線 Compatible Wire	2mm ²	3.5mm ²	5.5mm ²
推奨圧着端子 Recommended Crimp Terminal	R2-3	※R3.5-4	※R5.5-3N

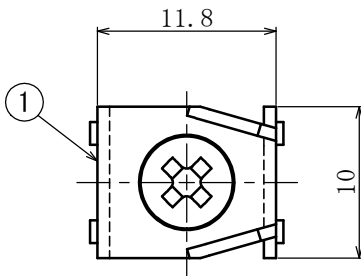

一般公差/General Tolerance ±0.5

尺度²/₁Scale²/₁ 単位/Unit mm

※適合電線3.5mm²及び5.5mm²使用時の圧着端子は“R3.5-4”及び“R5.5-3N”で使用可能

The crimp terminal when using the compatible wires 3.5 and 5.5mm² can be used with “R3.5-4” and “R5.5-3N”.

推奨圧着端子はニチフ(株)の圧着端子を基に選定しています。
The crimp terminals are selected based on the crimp terminals from Nichifu Co., Ltd.

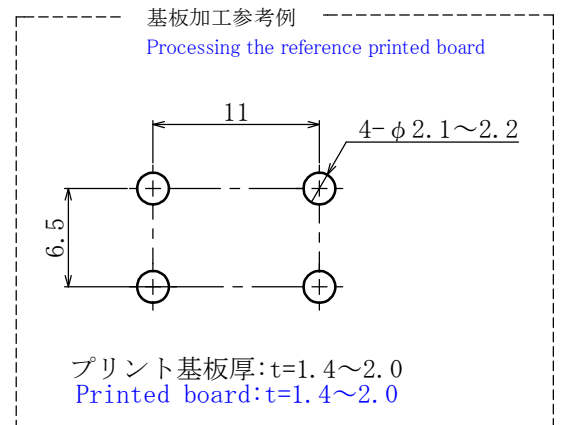
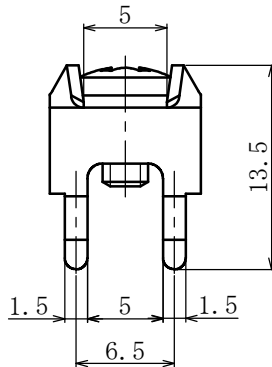
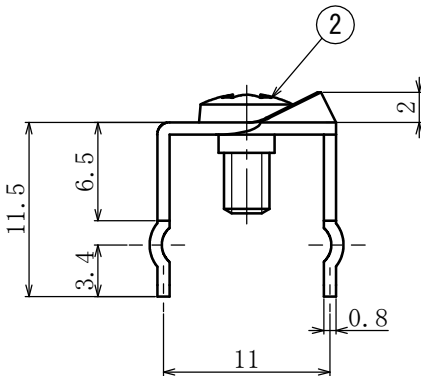

・注文方法: 型番 --- (下表の型番を御参照下さい。)

・Ordering Form: Type No. (See the type number in the following table)

仕様 Specifications

番号 Part No.	名称 Part Name	材質 Material	寸法 Size	規格 Standard	処理 Treatment
1	基板端子 Printed board Terminal	黄銅 Brass	板厚 t=0.8	C2680R	スズメッキ Tin-Plated
2	結線ビス Screw	黄銅 Brass	M3	C2700W	ニッケルメッキ Nickel-Plated

型番 Type No.	納入される物 Product Delivered
F4050A	基板端子のみ(ビスなし) Printed board terminal (for M3) only (W/O screws)
F4050AS	基板端子M3×6Lバインドビス(Type⑧)組付 Printed board terminal+M3×6L binding head attached (Type⑧)

対応可能ビス Compatible screw	材質 Material	処理 Treatment	形状 Shape
PW. SWセムスパインド M3×6L Type③With Plain(Flat)washer and spring lock washer M3×6L	黄銅 Brass	ニッケルメッキ Nickel-Plated	Type③
	鉄 steel		
SWセムスパインド M3×6L Type④With spring lock washer M3×6L	黄銅 Brass	ニッケルメッキ Nickel-Plated	Type④
PW. SWセムスナベ M3×7L Type⑤With Plain(Flat)washer and spring lock washer M3×7L	黄銅 Brass	ニッケルメッキ Nickel-Plated	Type⑤
	鉄 steel		
SWセムスナベ M3×7L Type⑦With spring lock washer M3×7L	黄銅 Brass	ニッケルメッキ Nickel-Plated	Type⑦